

*ONLY FOR 0-10V DIMMING / SEULEMENT POUR 0-10V DIMMING

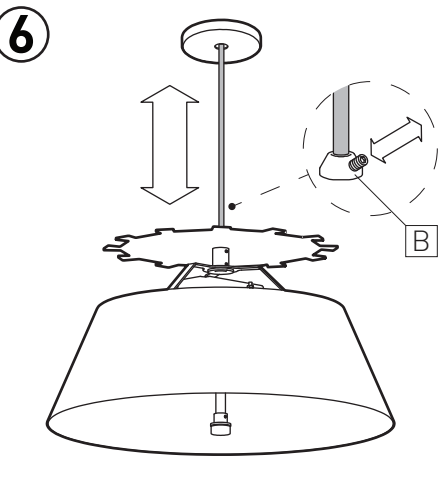
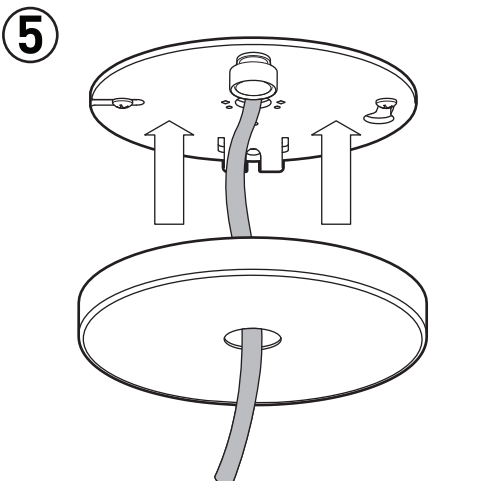
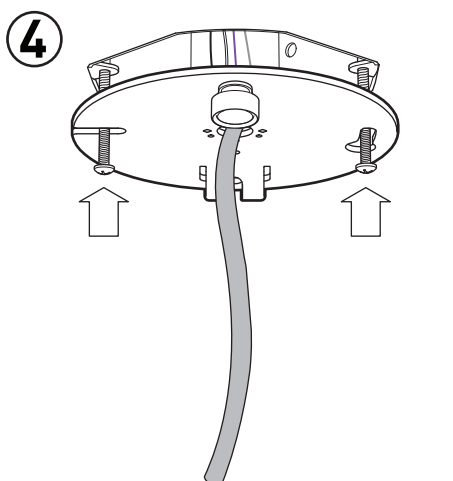

INSTALLATION

1- INSERT BOTH #8-32 SCREWS LEAVING A 1.0" DISTANCE BETWEEN THE SCREW HEAD AND THE JUNCTION BOX. HANG THE MOUNTING PLATE [A] ON ONE OF THE SCREW HEADS USING THE SLOT IN THE FOLDED FLAP

2- MAKE CONNECTIONS:

- *PURPLE WIRE (0-10V DIM +) = BLUE WIRE
- *GREY WIRE (0-10V DIM -) = WHITE WIRE
- BLACK WIRE (LINE) = BLACK WIRE
- WHITE WIRE (NEUTRAL) = RED WIRE

* ONLY FOR 0-10V DIMMING

3- DETACH MOUNTING PLATE FROM FOLDED FLAP AND FIX IN PLACE USING THE TWO KEYHOLE SLOTS

4- TIGHTEN DOWN SCREWS

5- LIFT CANOPY INTO POSITION

6- ADJUST FIXTURE'S HEIGHT BY LOOSENING THE SCREW ON THE STRAIN RELIEF [B] AND SLIDING THE CABLES TO DESIRED LENGTH, TIGHTEN BACK THE SCREW TO SECURE THE FIXTURE

INSTALLATION

1- INSÉRER LES DEUX VIS #8-32 EN LAISSANT UN ESPACE DE 1.0" ENTRE LES TÊTES DE VIS ET LA BOÎTE DE JONCTION. SUSPENDRE LA PLAQUE DE MONTAGE [A] SUR L'UNE DES VIS EN UTILISANT L'OUVERTURE DE L'AILLETTE

2- FAIRE LES CONNEXIONS:

- *FIL MAUVE (0-10V DIM +) = FIL BLEU
- *FIL GRIS (0-10V DIM -) = FIL BLANC
- FIL NOIR (PHASE) = FIL NOIR
- FIL BLANC (NEUTRE) = FIL ROUGE

* SEULEMENT POUR 0-10V DIMMING

3- DÉTACHER LA PLAQUE DE MONTAGE DE L'AILLETTE ET LA FIXER AU VIS À L'AIDE DES DEUX TROUS DE SERRURE

4- RESSÉRER LES VIS

5- LEVER LE PAVILLON EN POSITION

6- AJUSTER LA HAUTEUR DU LUMINAIRE EN DÉVISSANT LA VIS SUR LE SERRE CÂBLE [B] ET GLISSER LE CÂBLE À LA LONGUEUR DÉSIRÉE, RESERRER LA VIS POUR SÉCURISER LE LUMINAIRE



225 de Liège Ouest, Suite #200
 Montréal (QC), Canada H2P 1H4
 Tel : 514.385.3515 Fax : 514.385.4169
 www.eurekalighting.com



4258-16

7

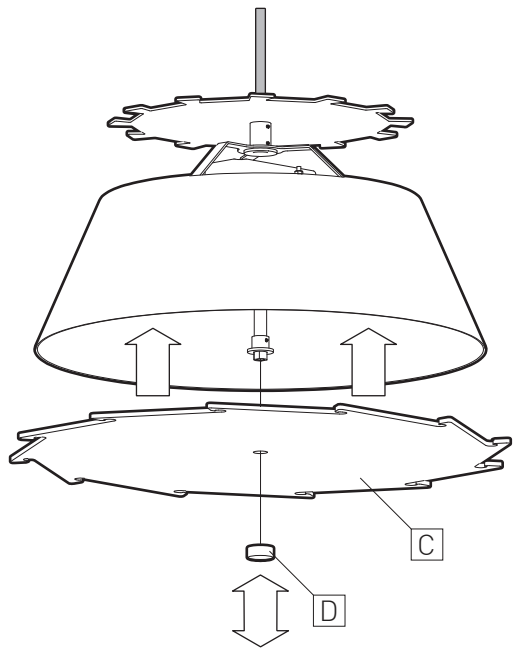

9

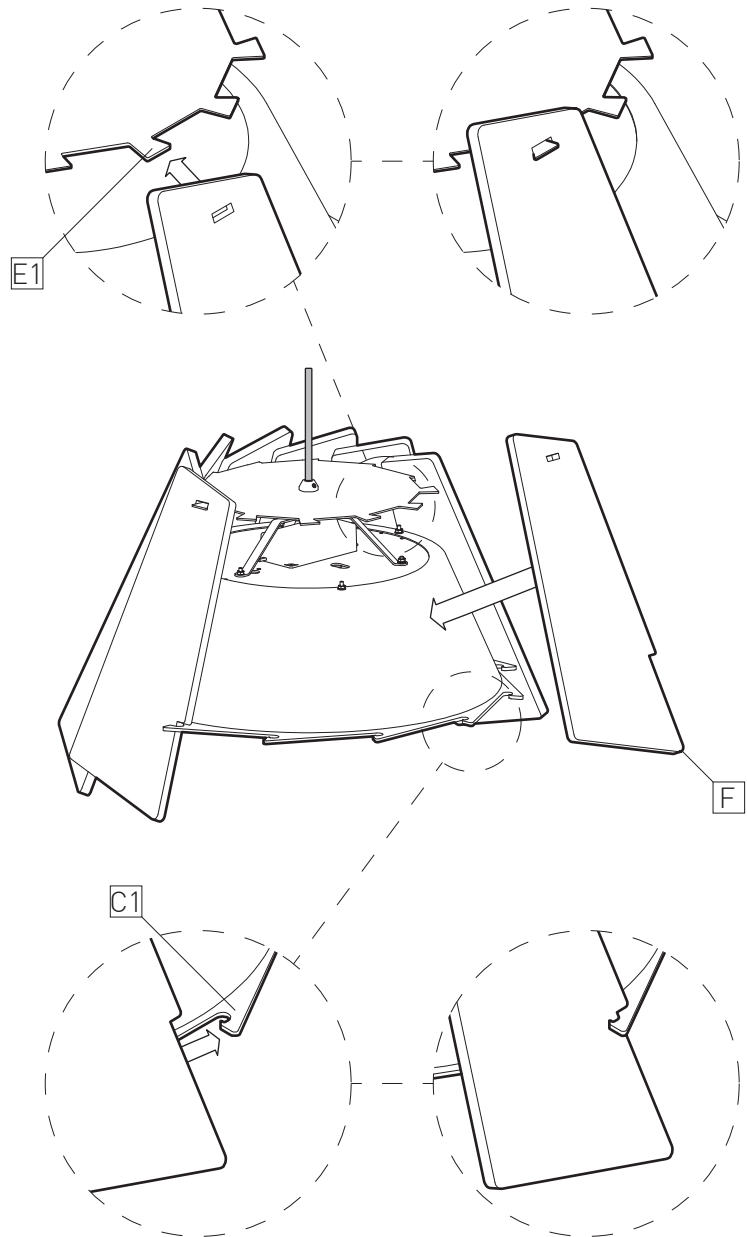

8

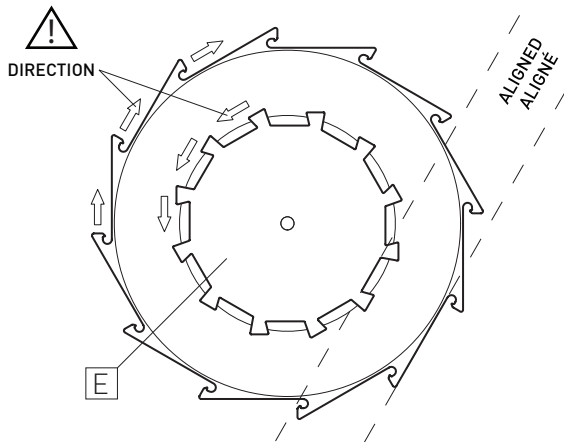

7- INSTALL DIFFUSER [C] BY REMOVING CAP [D] AND SECURE IN PLACE BY TIGHTENING CAP [D]

8- VERIFY PROPER DIRECTION OF METAL PLATE [E] AND DIFFUSER [C], ALIGN EDGE OF EACH SEGMENT OF METAL PLATE [E] WITH CORRESPONDING EDGE OF DIFFUSER [C]

9- INSERT THE TWELVE SHADE PANELS [F] BY HOOKING THE TOP PART OF THE PANEL THROUGH THE METAL PLATE FLANGES [E1] AND THE BOTTOM PART THROUGH THE DIFFUSEUR HOOKS [C1]

7- INSTALLER LE DIFFUSEUR [C] EN RETIRANT L'EMBOUT [D], PUIS SÉCURISER EN PLACE EN RESERRANT L'EMBOUT [D]

8- VÉRIFIER LA BONNE DIRECTION DE LA PLAQUE MÉTALLIQUE [E] ET DU DIFFUSEUR [C], ALIGNER LE REBORD DE CHAQUE SEGMENT DE LA PLAQUE [E] AVEC LE REBORD CORRESPONDANT DU DIFFUSEUR [C]

9- INSÉRER LES DOUZE PANNEAUX DE L'ABAT-JOUR [F] EN ACCROCHANT LA PARTIE SUPÉRIEURE AU TRAVERS LA LANGUETTE DE LA PLAQUE MÉTALLIQUE [E1] ET LE BAS DANS LE CROCHET DU DIFFUSEUR [C1]