

ATOLL ACOUSTIC 4853

SUSPENDED ACOUSTIC /SUSPENDU ACOUSTIQUE

2 PEOPLE REQUIRED FOR ASSEMBLY
2 PERSONNES REQUISES POUR L'ASSEMBLAGE

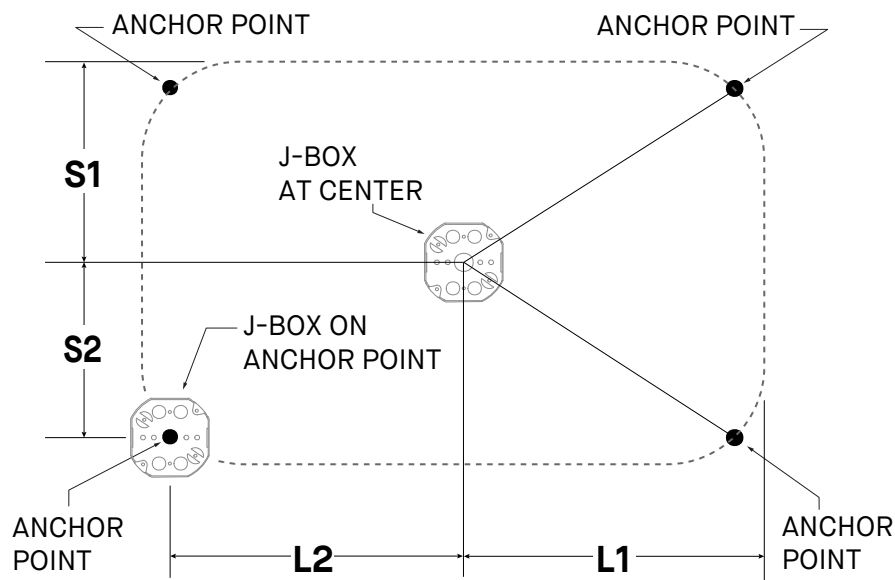

RECOMMENDED MINIMUM DISTANCE FROM CEILING
 (from the top of the fixture)

DISTANCE MINIMUM RECOMMANDÉE DU PLAFOND
 (à partir du haut du luminaire)

Batwing uplight lens :

| SIZE | 44X44 | 44X62 | 62X62 | OTHER SIZES |
|----------|-------|-------|-------|-------------|
| DISTANCE | 10" | 12" | 12" | 15" |

Lambertian uplight lens :

SIZE : ALL
 DISTANCE : 24" min. recommended.

Less distances are possible but will show a more concentrated area of illumination on the ceiling.

MOUNTING POINTS REFERENCE / RÉFÉRENCE DE POINTS D'ANCRAGE

| MODEL + WEIGHT/POIDS | L1 | L2 | S1 | S2 |
|---|---------------------|---------------------|---------------------|---------------------|
| 4852-44x44 (16.2LBS / 7.4KG) | 534mm 21" | 449mm 17 11/16" | 534mm 21" | 449mm 17 11/16" |
| 4852-44x62 (20LBS / 9.1KG) | 773mm 30 7/16" | 688mm 27 1/8" | 534mm 21" | 449mm 17 11/16" |
| 4852-44x82 (23.8LBS / 10.8KG) | 1031mm 40 5/8" | 1014mm 39 15/16" | 534mm 21" | 449mm 17 11/16" |
| 4852-44x100 (27.6LBS / 12.5KG) | 1254mm 49 3/8" | 1167mm 45 5/16" | 534mm 21" | 449mm 17 11/16" |
| 4852-44x120 (31.4LBS / 14.3KG) | 1494mm 58 13/16" | 1409mm 55 7/16" | 534mm 21" | 449mm 17 11/16" |
| 4852-62x62 (23.8LBS / 10.8KG) | 773mm 30 7/16" | 688mm 27 1/8" | 773mm 30 7/16" | 688mm 27 1/8" |
| 4852-62x82 (27.6LBS / 12.5KG) | 1031mm 40 5/8" | 1014mm 39 15/16" | 773mm 30 7/16" | 688mm 27 1/8" |
| 4852-62x100 (31.4LBS / 14.3KG) | 1254mm 49 3/8" | 1167mm 45 5/16" | 773mm 30 7/16" | 688mm 27 1/8" |
| 4852-62x120 (35.2LBS / 16KG) | 1494mm 58 13/16" | 1409mm 55 7/16" | 773mm 30 7/16" | 688mm 27 1/8" |
| 4852-82x82 (35.2LBS / 16KG) | 1031mm 40 5/8" | 1014mm 39 15/16" | 1031mm 40 5/8" | 1014mm 39 15/16" |
| 4852-82x100 (35.2LBS / 16KG) | 1254mm 49 3/8" | 1167mm 45 5/16" | 1031mm 40 5/8" | 1014mm 39 15/16" |
| 4852-82x120 (39LBS / 17.7KG) | 1494mm 58 13/16" | 1409mm 55 7/16" | 1031mm 40 5/8" | 1014mm 39 15/16" |
| 4852-100x100 (39LBS / 17.7KG) | 1254mm 49 3/8" | 1167mm 45 5/16" | 1254mm 49 3/8" | 1167mm 45 5/16" |
| 4852-100x120 (42.8LBS / 19.5KG) | 1494mm 58 13/16" | 1409mm 55 7/16" | 1254mm 49 3/8" | 1167mm 45 5/16" |
| 4852-120x120 (46.6LBS / 21.2KG) | 1494mm 58 13/16" | 1409mm 55 7/16" | 1494mm 58 13/16" | 1409mm 55 7/16" |

CANOPY LOCATION / EMPLACEMENT DE PAVILLON

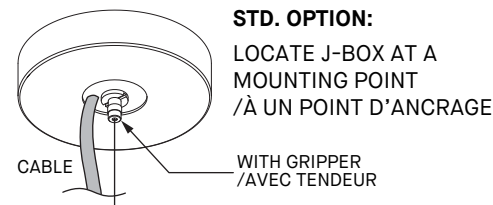

STD. OPTION:

LOCATE J-BOX AT A MOUNTING POINT
 /À UN POINT D'ANCRAGE

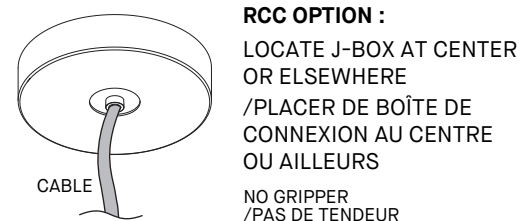

RCC OPTION :

LOCATE J-BOX AT CENTER OR ELSEWHERE
 /PLACER DE BOÎTE DE CONNEXION AU CENTRE OU AILLEURS

NO GRIPPER
 /PAS DE TENDEUR

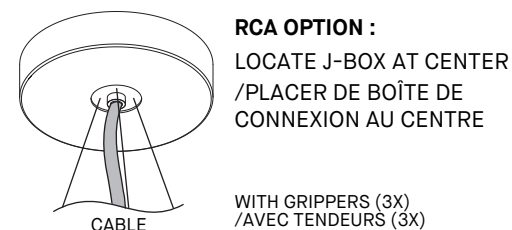

RCA OPTION :

LOCATE J-BOX AT CENTER
 /PLACER DE BOÎTE DE CONNEXION AU CENTRE

WITH GRIPPERS (3X)
 /AVEC TENDEURS (3X)

ATOLL ACOUSTIC 4853

SUSPENDED ACOUSTIC /SUSPENDU ACOUSTIQUE

1 STATE OF FIXTURE /ÉTAT DE LA FIXTURE

IF FIXTURE IS ALREADY ASSEMBLED → SKIP TO STEP 5
 SI FIXTURE DÉJÀ ASSEMBLÉE → SAUTER À L'ÉTAPE 5

IF FIXTURE IS DISASSEMBLED → CONTINUE TO STEP 2
 SI FIXTURE EST DÉASSEMBLÉE → CONTINUER À L'ÉTAPE 2

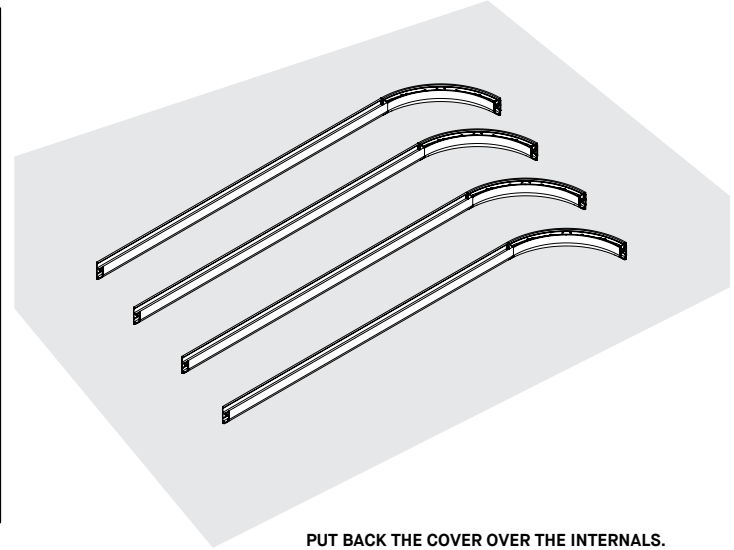
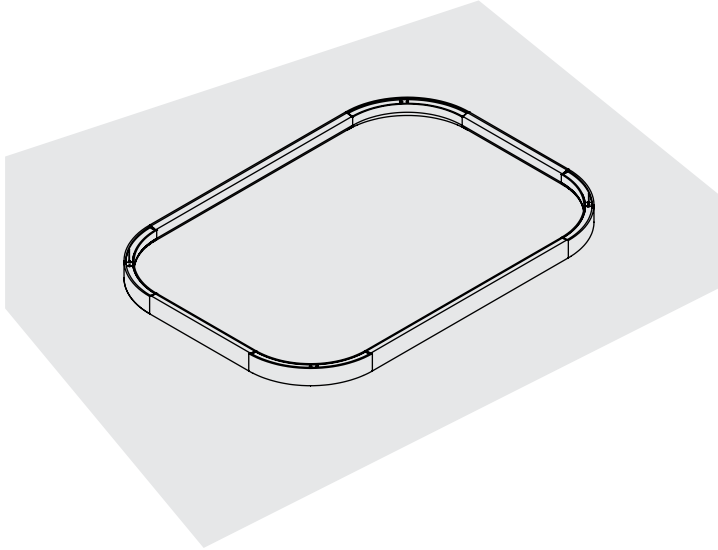

PUT BACK THE COVER OVER THE INTERNALS.
 REMETTRE LE COUVERT SUR LES PARTIES INTERNES.

2 LIFT UP THE COVER WITH A FLAT-HEAD SCREWDRIVER, REVEALING THE INTERNALS. /LEVER LE COUVERT AVEC UN TOURNE-VIS À TÊTE PLATE, MONTRANT LA PARTIE INTERNE.

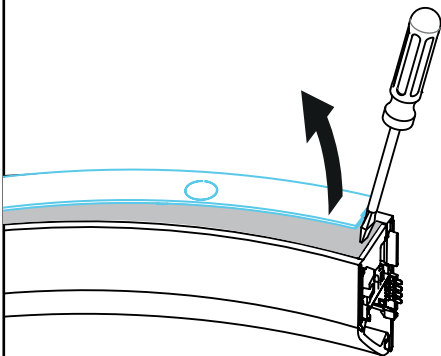

3A CONNECT WIRES IF PRESENT CONNECTER LES FILS S'ILS SONT PRÉSENTS

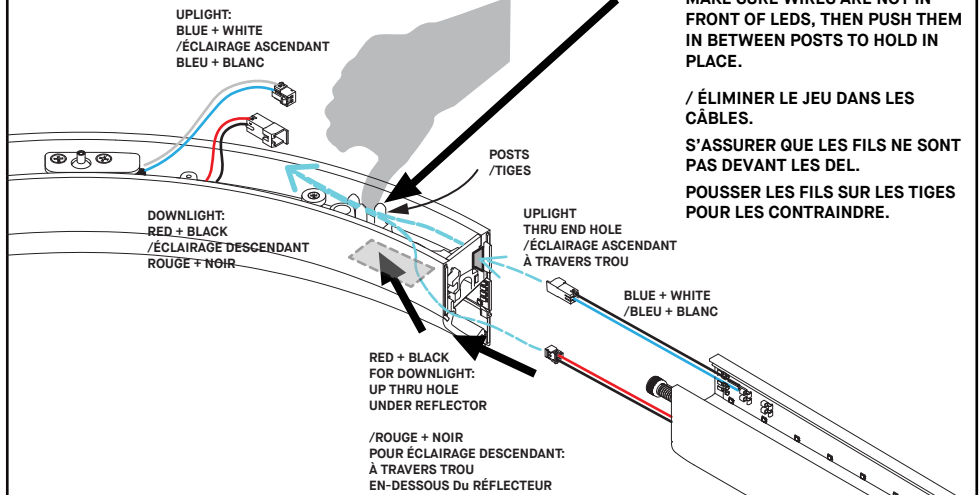

3B REMOVE SLACK FROM WIRES. MAKE SURE WIRES ARE NOT IN FRONT OF LEDS, THEN PUSH THEM IN BETWEEN POSTS TO HOLD IN PLACE. /ÉLIMINER LE JEU DANS LES CÂBLES. S'ASSURER QUE LES FILS NE SONT PAS DEVANT LES DEL. POUSSER LES FILS SUR LES TIGES POUR LES CONTRAINDRE.

INSTALLATION

1- DEPENDING ON THE SIZE OF THE FIXTURE, IT IS POSSIBLE THAT IT IS ALREADY ASSEMBLED. IN THIS CASE, SKIP TO STEP 6.

OTHERWISE, THE FIXTURE IS IN FOUR (4) PIECES IN A "J" SHAPE, AND WILL BE REQUIRED TO BE ASSEMBLED. CONTINUE WITH STEP 2.

2 TO 3B- FOLLOW ON-DRAWING INSTRUCTIONS.

INSTALLATION

1- SELON LA GRANDEUR DE LA FIXTURE, IL EST POSSIBLE QU'ELLE SOIT DÉJÀ ASSEMBLÉE. DANS CE CAS, SAUTER À L'ÉTAPE 6.

SINON, LA FIXTURE EST EN QUATRE (4) MORCEAUX EN FORME DE «J», ET DEVRA ÊTRE ASSEMBLÉE. CONTINUER AVEC L'ÉTAPE 2.

2 À 3B- SUIVRE LES INSTRUCTIONS SUR DESSINS.

ATOLL ACOUSTIC 4853

SUSPENDED ACOUSTIC /SUSPENDU ACOUSTIQUE

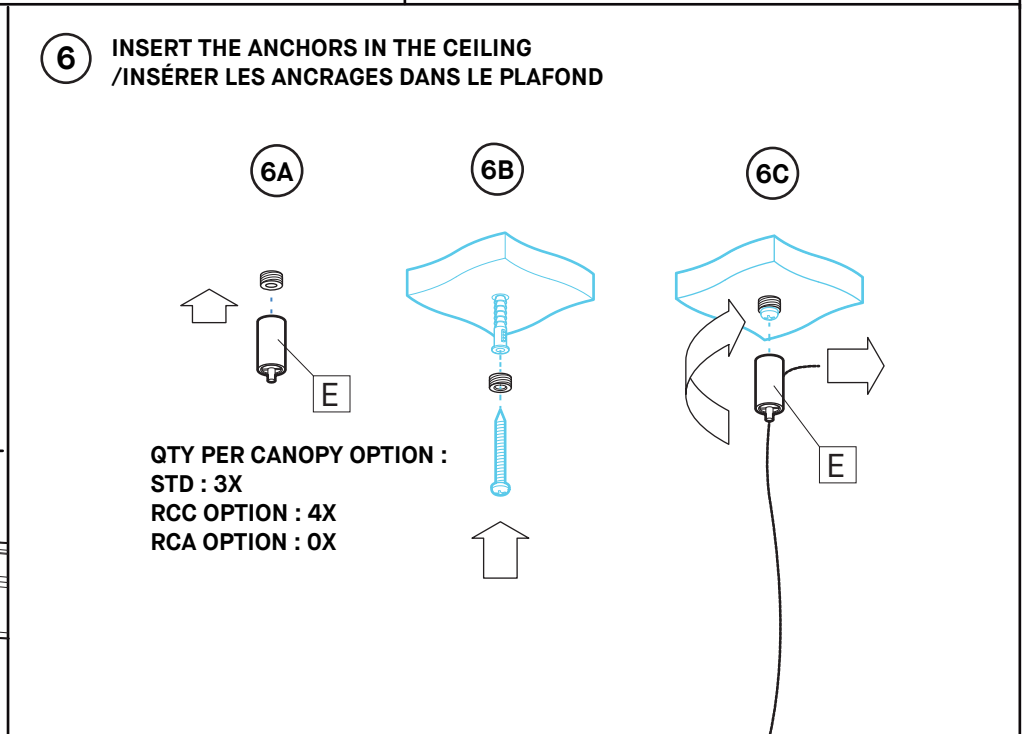
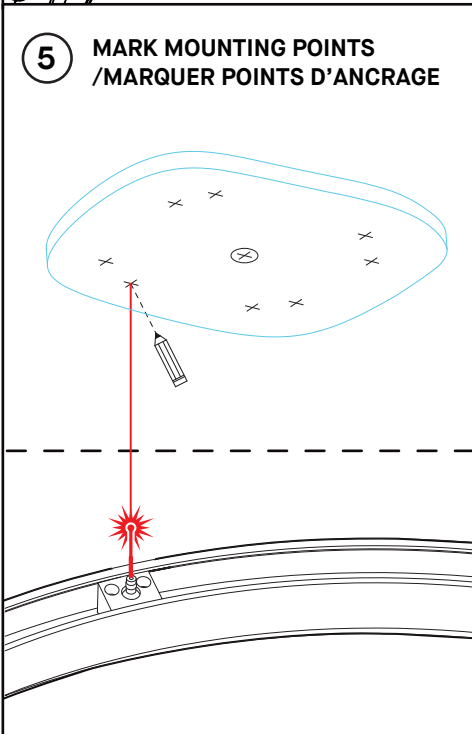
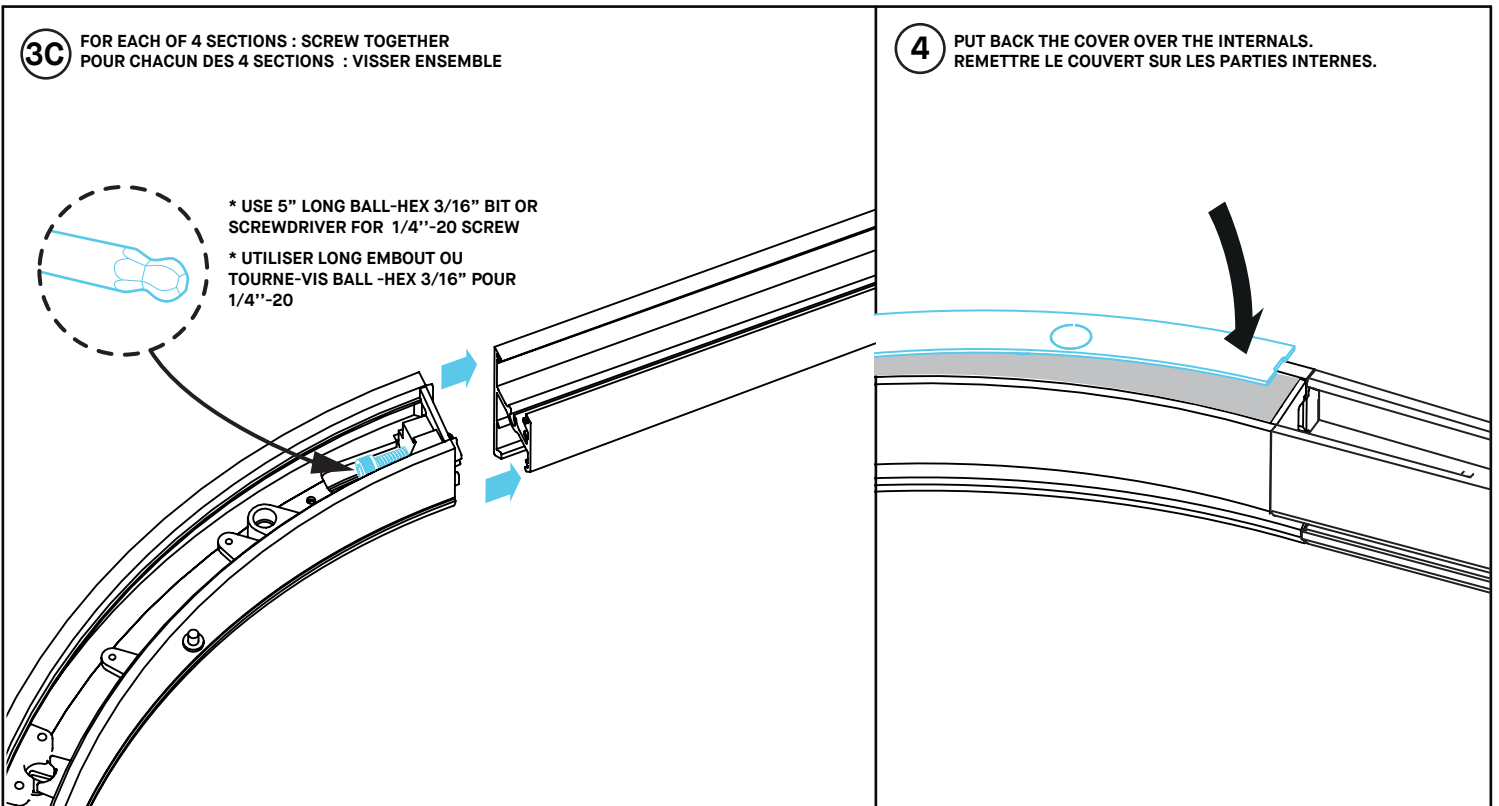

INSTALLATION

3C TO 4- FOLLOW ON-DRAWING INSTRUCTIONS.

5- USING A LASER POINTER ALIGNED WITH THE GRIPPERS ON THE FIXTURE, MARK DESIRED MOUNTING POINTS ON CEILING.

6- INSERT THE ANCHORS [NOT SUPPLIED] IN THE CEILING FOLLOWING THE MARKINGS MADE ON STEP 1. INSTALL THE GRIPPERS [E] ON THE MOUNTING POINTS USING

INSTALLATION

3C À 4- SUIVRE LES INSTRUCTIONS SUR DESSINS.

5- UTILISANT UN POINTEUR AU LASER ALIGNÉ AVEC LES TENDEURS DU LUMINAIRE, MARQUER LES POINTS D'ANCRAGE DÉSIRÉS SUR LE PLAFOND.

6- INSÉRER LES CHEVILLES [NON FOURNIES] AU PLAFOND EN RESPECTANT LES MARQUES CRÉÉES À L'ÉTAPE 1. INSTALLER LES TENDEURS [E] SUR LES POINTS

ATOLL ACOUSTIC 4853

SUSPENDED ACOUSTIC /SUSPENDU ACOUSTIQUE

7

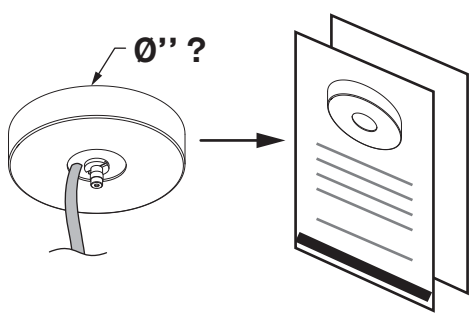

IDENTIFY CANOPY INSTALL SHEET(S) AND FOLLOW STEPS

/IDENTIFIER PAGE(S) DE PAVILLON ET SUIVRE ÉTAPES

8

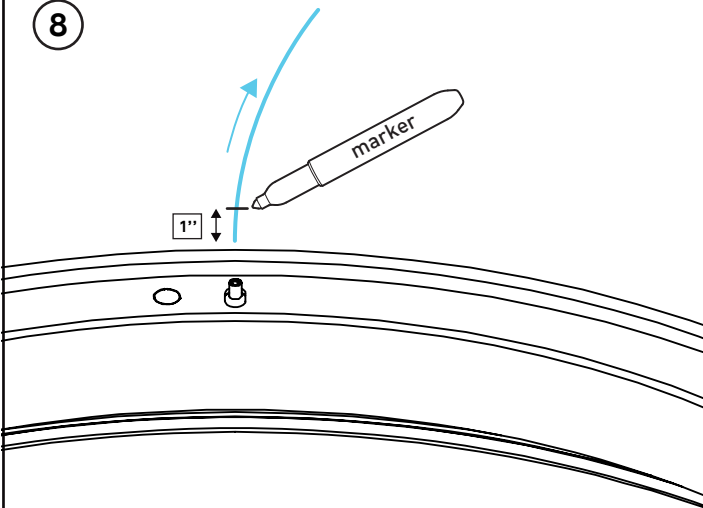

9

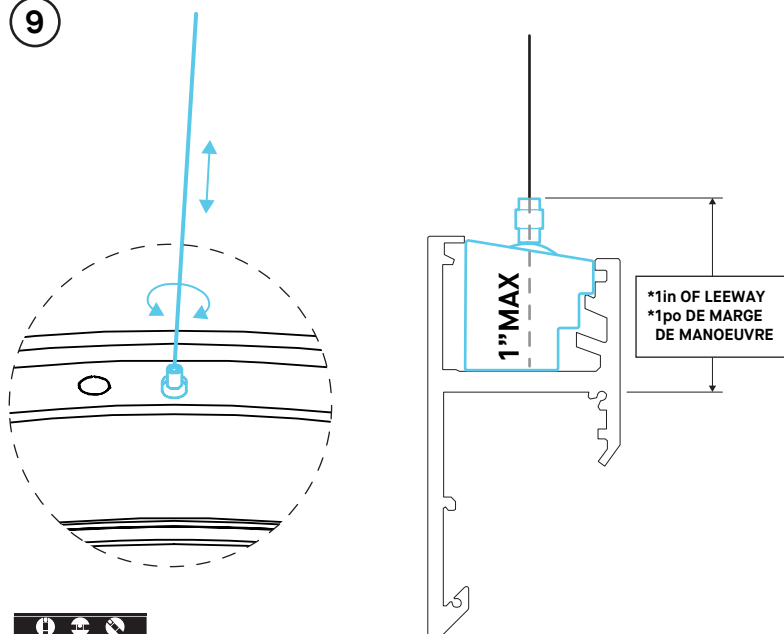

ATTENTION
LEVEL THE FIXTURE DURING HEIGHT ADJUSTMENT/
NIVELLER LE LUMINAIRE DURANT L'AJUSTEMENT
DE HAUTEUR

SECTIONAL VIEW
VUE DE COUPE

1" MAX

***1in OF LEEWAY**
***1po DE MARGE DE MANOEUVRE**

CANOPY LOCATION : STD
POSITION PAVILLON : STD

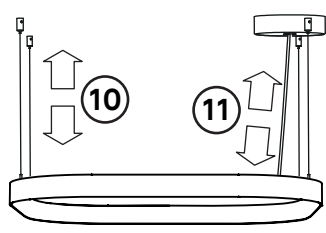

CANOPY LOCATION : RCC
POSITION PAVILLON : RCC

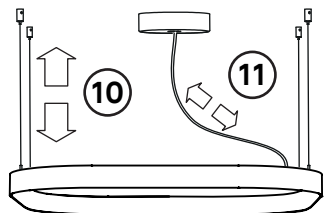

CANOPY LOCATION : RCA
POSITION PAVILLON : RCA

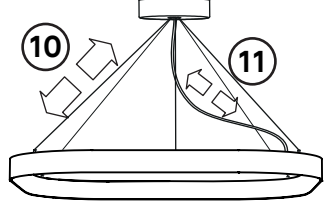

INSTALLATION

- 7- IDENTIFY THE INSTALLATION GUIDE FOR CHOSEN CANOPY AND INSTALL CANOPY TO CEILING.
- 8- TAKE OUT AIRCRAFT CABLES FROM CABLE GRIPPERS ON FIXTURE. MEASURE 1in AWAY FROM THE EXTREMITY OF THE CABLE AND LEAVE A MARK USING A MARKER.
- 9- INSERT AIRCRAFT CABLES BACK IN THE CABLE GRIPPERS ON FIXTURE. ADJUST CABLE LENGTH TO LEVEL THE FIXTURE AS DESIRED.
- !!! NO MORE THAN 1in CAN GO INSIDE THE CABLE GRIPPER - ANY EXCESS WOULD AFFECT ILLUMINATION !!!**
- 10- ADJUST CABLE LENGTH TO LEVEL THE FIXTURE AS DESIRED.
- 11- ADJUST LENGTH OF POWER CABLE TO CREATE AN EVEN CURVE.

INSTALLATION

- 7- IDENTIFIER LE GUIDE D'INSTALLATION DU PAVILLON CHOISI ET INSTALLER LE PAVILLON AU PLAFOND.
- 8- SORTIR LES CÂBLE EN ACIER DES TENDEURS SITUÉS SUR LE LUMINAIRE. MESURER 1po À PARTIR DE L'EXTRÉMITÉ DU CÂBLE ET MARQUER À L'AIDE D'UN MARQUEUR.
- 9- INSÉRER LES CÂBLES EN ACIER DANS LES TENDEURS SITUÉS SUR LE LUMINAIRE. AJUSTER LA LONGUEUR DES CÂBLES POUR NIVELLER LE LUMINAIRE.
- !!! NE PAS INSÉRER PLUS QU'1po DANS LE TENDEUR - TOUT EXCÈS PEUT AFFECTER L'ILLUMINATION DU LUMINAIRE !!!**
- 10- AJUSTER LA LONGUEUR DES CÂBLES POUR NIVELLER LE LUMINAIRE.
- 11- AJUSTER LA LONGUEUR DU CÂBLE D'ALIMENTATION POUR CRÉER UNE COURBE RÉGULIÈRE.

ATOLL ACOUSTIC 4853
SUSPENDED ACOUSTIC /SUSPENDU ACOUSTIQUE

ASSEMBLY DEPENDING ON SIZE / ASSEMBLAGE SELON LA GRANDEUR

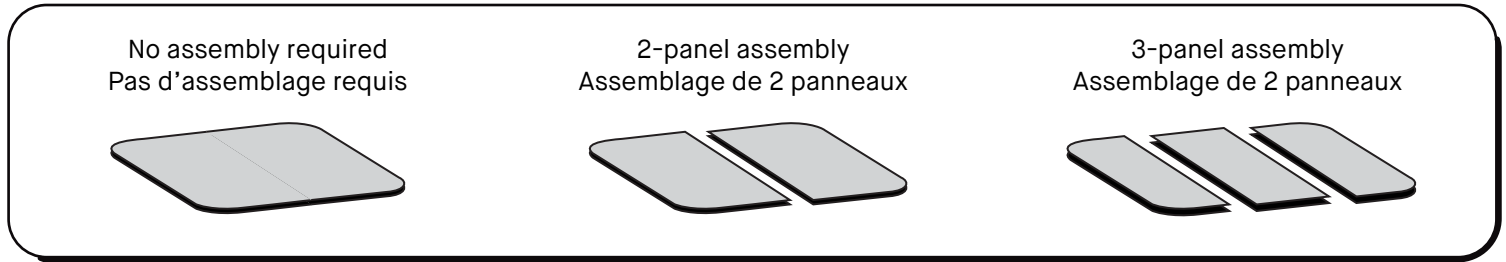

**SUPPORT FELT PANELS PROPERLY DURING HANDLING TO KEEP THEM FLAT. BENDING MAY DAMAGE THEM.
 BIEN SUPPORTER LES PANNEAUX DE FEUTRE LORS DE LEUR MANIPULATION AFIN DE LES MAINTENIR PLAT.
 LE PLIAGE PEUT LES ENDOMMAGER.**

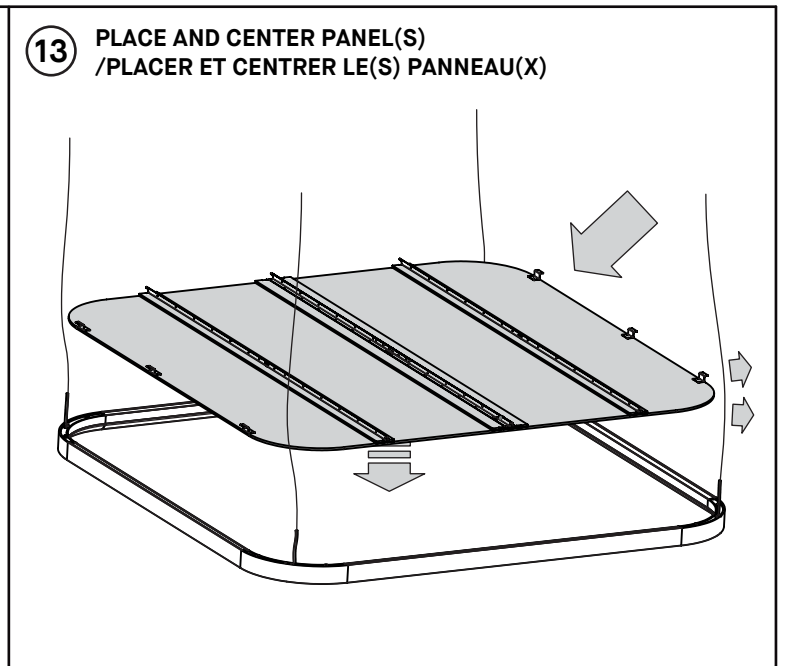
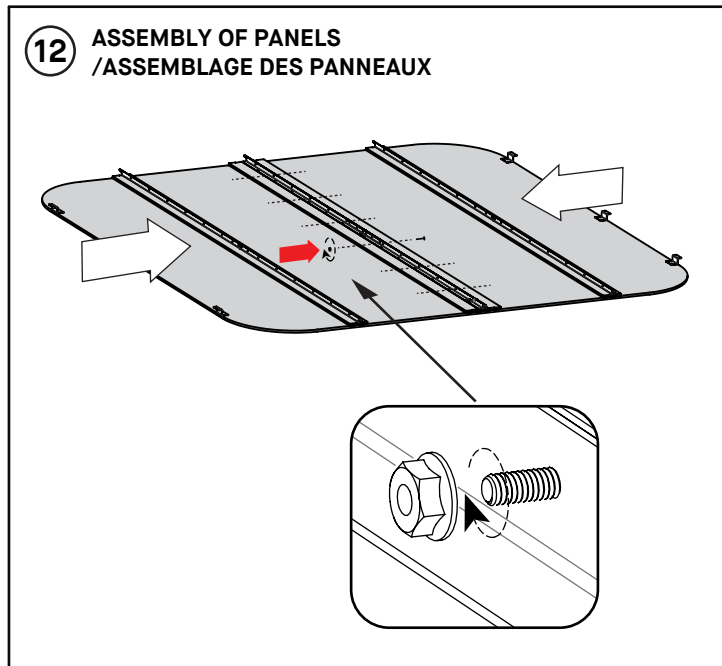
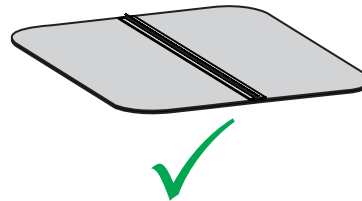
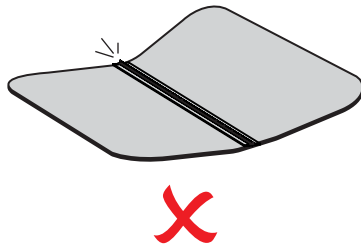

INSTALLATION

- 12- IF REQUIRED, ASSEMBLE PANELS WITH PROVIDED SCREWS.
- 13- CAREFULLY PLACE AND CENTER PANEL(S) INTO FIXTURE.

INSTALLATION

- 12- SI REQUIS, ASSEMBLER LES PANNEAUX AVEC LES VIS FOURNIES.
- 13- PLACER SOIGNEUSEMENT ET CENTRE LE OU LES PANNEAUX DANS LA FIXTURE.

ATOLL ACOUSTIC 4853
SUSPENDED ACOUSTIC /SUSPENDU ACOUSTIQUE

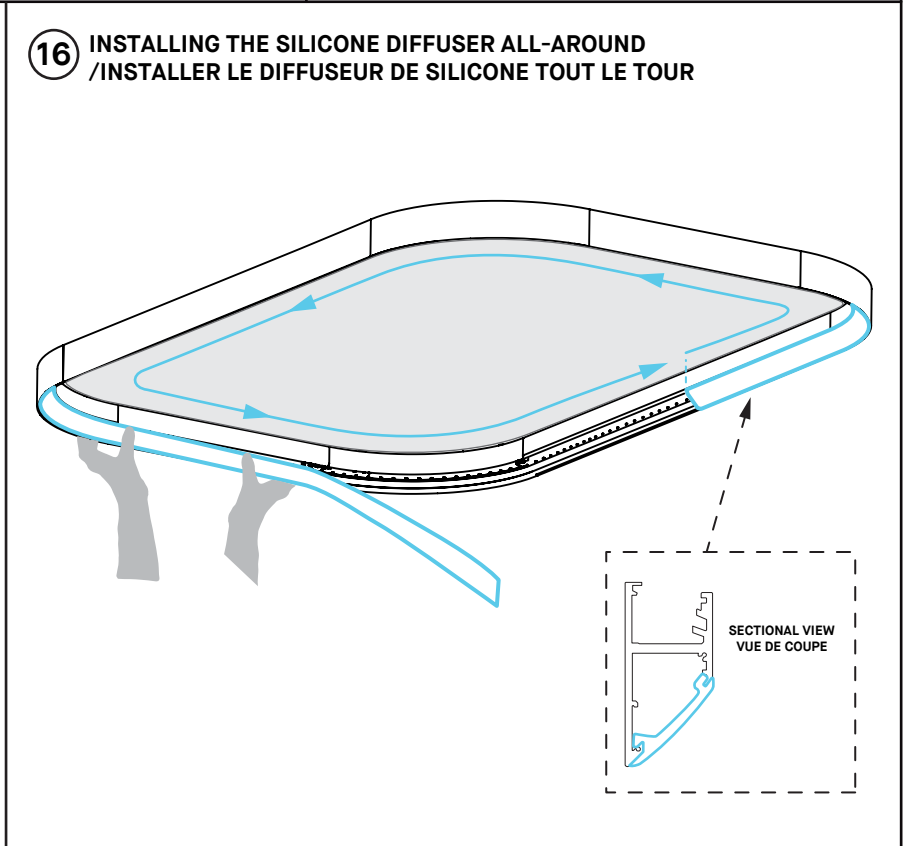
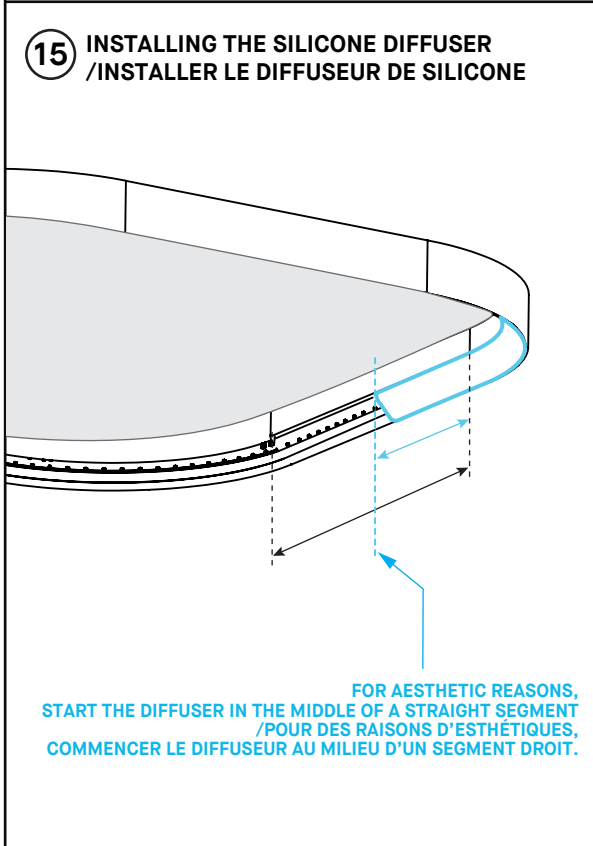
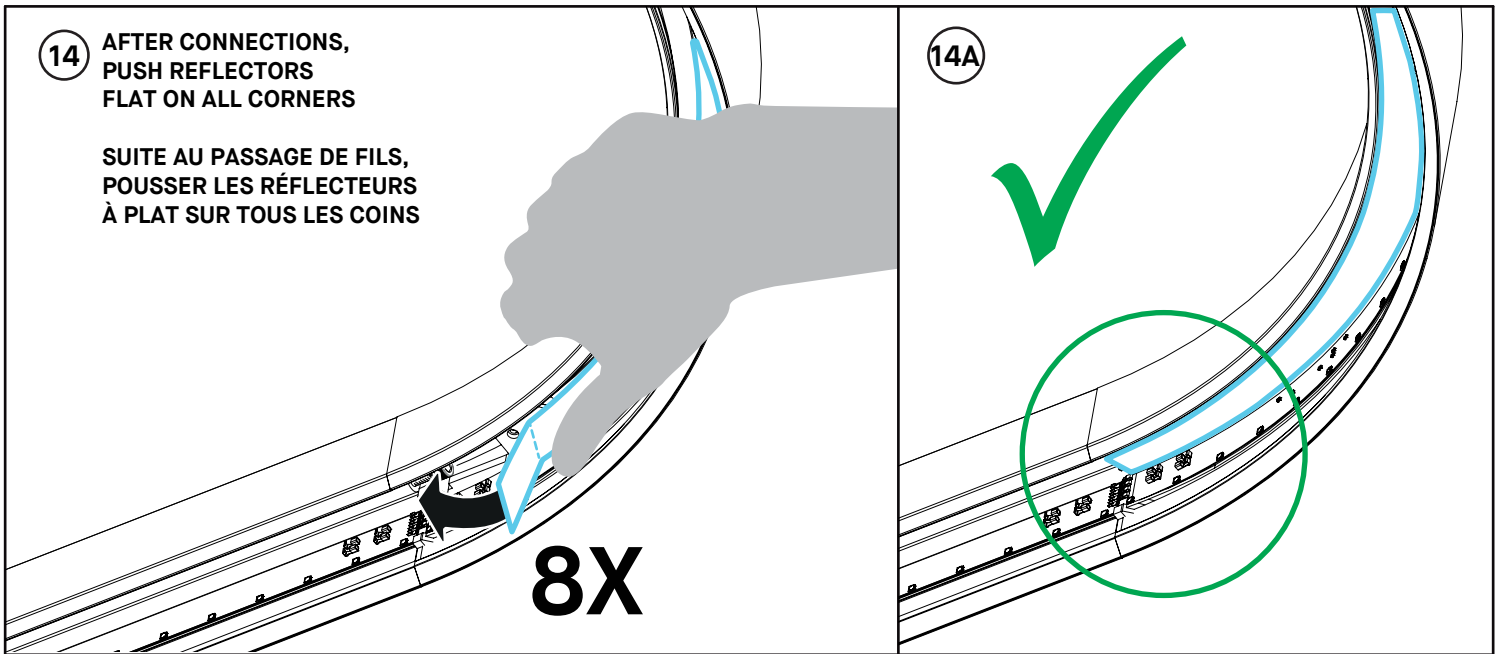

INSTALLATION

14- PUSH REFLECTORS FLAT ON ALL 8 CORNERS.

14A- MAKE SURE ALL REFLECTORS ARE FLAT.

15- INSERT THE START THE DIFFUSER WITH THE MIDDLE OF A STRAIGHT SEGMENT.

16- INSERT THE REST OF THE DIFFUSER IN THE FIXTURE.

!!! BE CAREFUL OF LED IN FIXTURE !!!

INSTALLATION

14- POUSSER LES RÉFLECTEURS À PLATS AUX 8 COINS.

14A- S'ASSURER QUE LES RÉFLECTEURS SONT À PLATS

15- INSÉRER LE DÉBUT DU DIFFUSEUR AU MILIEU D'UN SEGMENT DROIT DE LA FIXTURE.

16- INSÉRER LE RESTE DU DIFFUSEUR DANS LA FIXTURE.

!!! FAITES ATTENTION AU DEL DANS LE LUMINAIRE !!!



INSTALLATION

ATOLL ACOUSTIC 4853

SUSPENDED ACOUSTIC /SUSPENDU ACOUSTIQUE

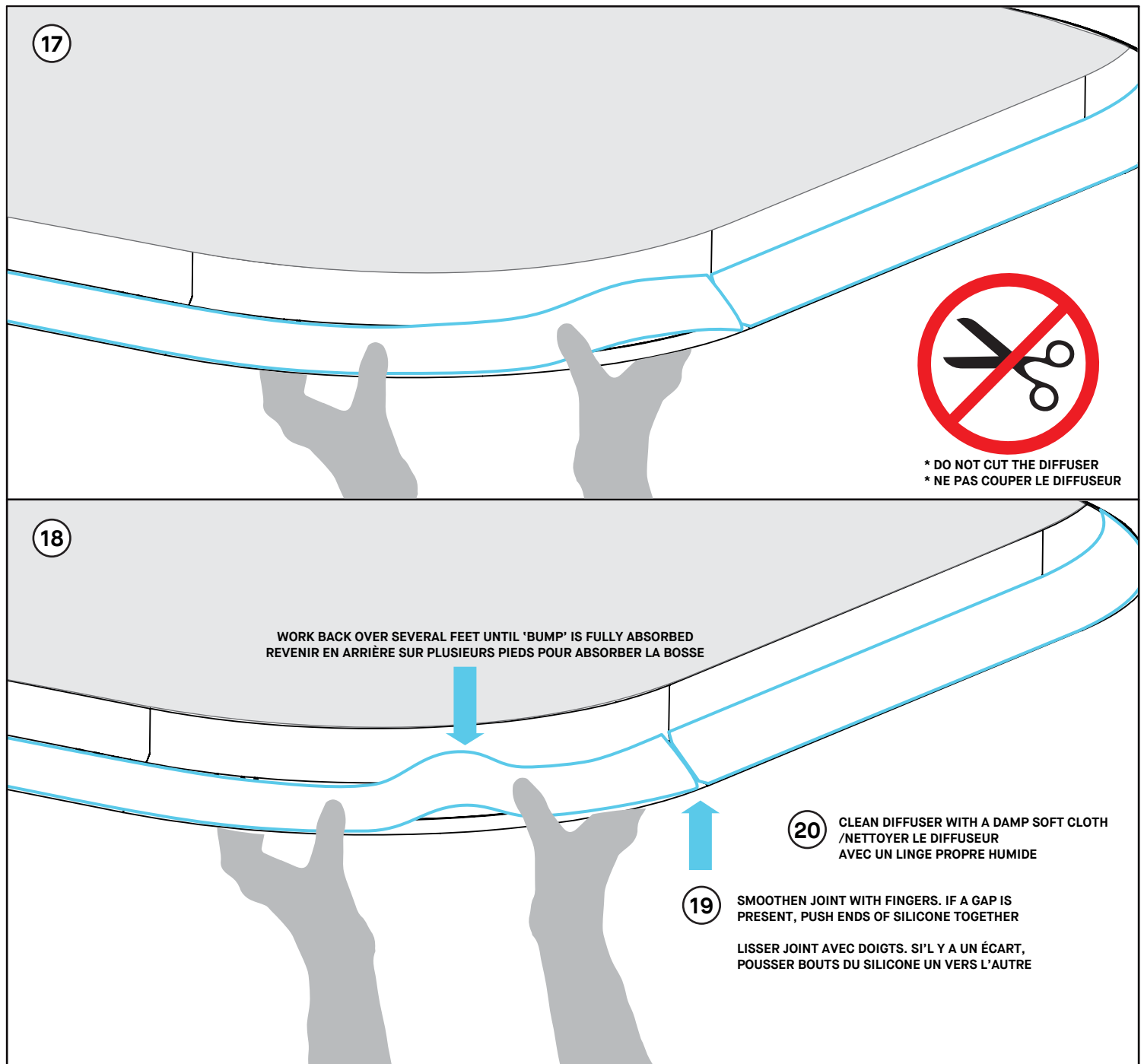

INSTALLATION

- 17- WHEN THERE IS APPROXIMATELY 4 FEET LEFT TO INSTALL, TAKE THE END OF THE LENS, INSERT AND PRESS AGAINST THE OTHER EXTREMITY TO CREATE A CLOSED JOINT.
- 18- GRADUALLY INSERT THE LENS FROM THE JOINT AND **WORK BACK UNTIL ONE OR SEVERAL 'BUMPS' ARE FULLY ABSORBED THROUGH COMPRESSION OF THE LENS MATERIAL. IF NEEDED**, REMOVE MORE OF THE LENS TO ABSORB THE 'BUMP'.
- 19- SMOOTHEN JOINT WITH FINGERS. IF A GAP IS PRESENT, PUSH ENDS OF SILICONE TOGETHER.
- 20- CLEAN DIFFUSER WITH A DAMP SOFT CLOTH.

INSTALLATION

- 17- LORSQU'IL RESTE ENVIRON 4 PIEDS À INSTALLER, PRENEZ L'EXTRÉMITÉ DE LA LENTILLE ET INSÉREZ ET LA PRESSER CONTRE L'AUTRE EXTRÉMITÉ POUR CRÉER UN JOINT FERMÉ.
- 18- INSÉREZ PROGRESSIVEMENT LA LENTILLE À PARTIR DU JOINT ET REVENEZ EN ARRIÈRE JUSQU'À CE QU'UNE OU PLUSIEURS « BOSSES » SOIENT ENTIÈREMENT ABSORBÉES PAR LA COMPRESSION DU MATÉRIAU DE LA LENTILLE. SI NÉCESSAIRE, RETIREZ PLUS DE LONGUEUR DE LA LENTILLE POUR POUVOIR ENSUITE ABSORBER LA « BOSSE ».
- 19- LISSER JOINT AVEC DOIGTS. SI'L Y A UN ÉCART, POUSSER BOUTS DU SILICONE UN VERS L'AUTRE.
- 20- NETTOYER LE DIFFUSEUR AVEC UN LINGE PROPRE HUMIDE.