

# EMPRESS 4235

PROJECT PROJÉT
SPEC TYPE
NOTES



## FAMILY FAMILLE



3035-22 (CEILING SURFACE) 3035-22 (WALL SURFACE)

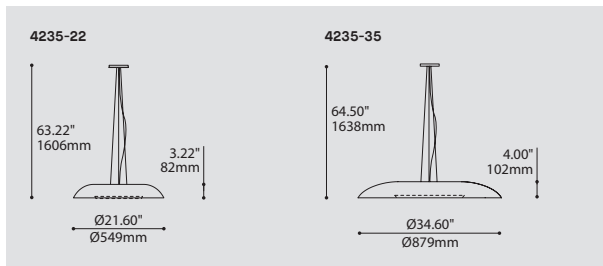

ORDERING SPECIFICATION	SPÉCIFICATION DE COMMANDE	CODE
<b>MODEL</b> MODÈLE		
4235-22	EMPRESS 22"	
4235-35	EMPRESS 35"	
<b>LIGHT SOURCE</b> SOURCE LUMINEUSE		<b>LED</b>
<b>LED</b>	REGULAR OUTPUT	
<b>COLOR TEMPERATURE</b> TEMPÉRATURE DE COULEUR		
27*	2700K	
30	3000K	
35	3500K	
40	4000K	
* LONGER LEAD TIME MAY APPLY, PLEASE CONTACT YOUR EUREKA REPRESENTATIVE		
<b>COLOR RENDERING INDEX (CRI)</b> INDICE DE RENDU DE COULEUR (IRC)		
80	80+ CRI	
90*	90+ CRI	
* LONGER LEAD TIME MAY APPLY, PLEASE CONTACT YOUR EUREKA REPRESENTATIVE		
<b>VOLTAGE</b> VOLTAGE		
120V	120 VOLT	
277V	277 VOLT	
<b>DIMMING OPTION</b> OPTION DE GRADATION		
DV	0-10V DIMMING (120V-277V)	
DP	PHASE DIMMING (120V ONLY)	
LED DIMMING DRIVER IS STANDARD IN THIS PRODUCT. PLEASE SPECIFY YOUR DIMMING TYPE		
<b>CABLE</b> CÂBLE		<b>AC</b>
AC	AIRCRAFT MOUNTING & CLEAR CABLE, FIELD ADJUSTABLE	
<b>CABLE LENGTH</b> LONGUEUR DE CÂBLE		
60	60" AIRCRAFT CABLE (STD LENGTH)	
**	CUSTOM AIRCRAFT CABLE LENGTH (PLEASE SPECIFY)	
FOR OVERALL LENGTH, PLEASE CONTACT YOUR EUREKA REPRESENTATIVE		
<b>CANOPY FINISH</b> FINI STRUCTURE		<b>WHE</b>
WHE	WHITE FINE TEXTURE	
<b>DECORATIVE PLATE FINISH</b> FINI PLAQUE DÉCORATIVE		<b>WHE</b>
WHE	WHITE FINE TEXTURE	
<b>DIFFUSER FINISH</b> FINI DIFFUSEUR		<b>WH</b>
WH	WHITE	
<b>ACCESSORY</b> ACCESSOIRE		
3983	DEEP JUNCTION BOX (PROVIDED FOR 4235-22)	

## PRODUCT CHARACTERISTICS CARACTÉRISTIQUES DU PRODUIT

**BIM** **DIM** **IES** **LED**

- DESIGN:** Now available in two formats, this ceiling mount brings a gentle diffused indirect light and quiet sophistication to your interior space.
- INSTALLATION:** Comes with an easy-to-install triple aircraft cable configuration.
- LIGHT SOURCE:** LED source creating an indirect light with a subtle back illumination.
- STRUCTURE:** Die spun steel plate, available in white fine textured finish.
- DIFFUSER:** Thermoformed matte white acrylic with frosted finish for optimal light diffusion. Available in 22" or 35" diameter.
- CERTIFIED:** c-CSA-us
- CONCEPTION:** Maintenant offert en deux formats, ce plafonnier apportera un éclairage indirect et délicatement diffus à votre espace.
- INSTALLATION:** Installation simplifiée avec trois câbles d'acier de type aviation.
- SOURCE LUMINEUSE:** Module DEL créant un éclairage indirect frontal et une légère illumination arrière.
- STRUCTURE:** Fait d'acier repoussé et offert avec notre finition architecturale blanche finement texturée.
- DIFFUSEUR:** Acrylique mat thermoformé et givré pour une diffusion lumineuse optimale. Offert en diamètres de 22" et 35".
- CERTIFIÉ:** c-CSA-us

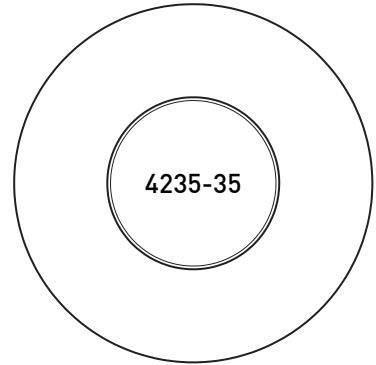
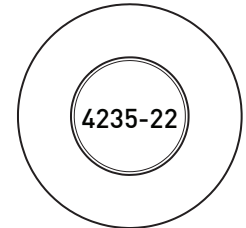
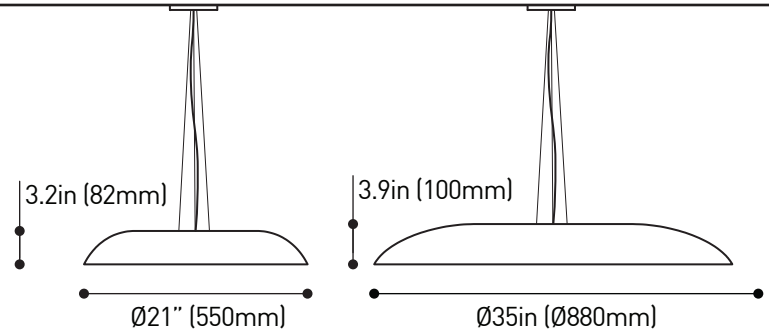
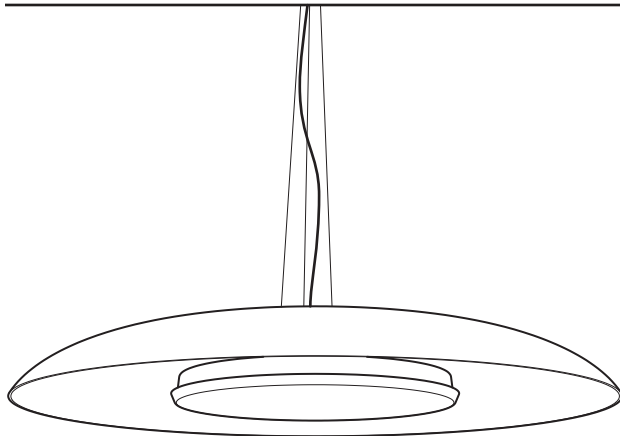

## INDIRECT AND AMBIENT LIGHT

Design for a principal indirect lighting with an ambient outer glow. Empress is suited for many installation context.

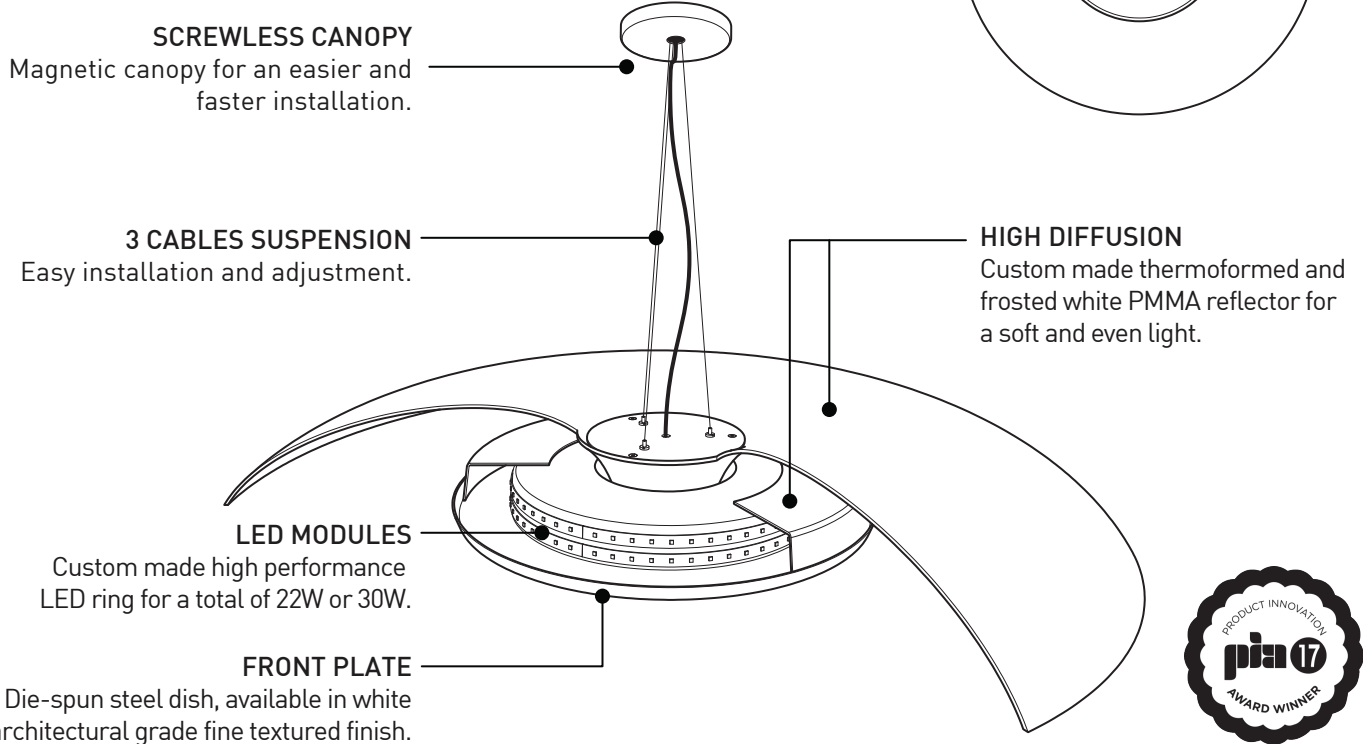

CHARACTERISTICS	4235-22	4235-35
LIGHT SOURCE	78 x Nichia	156 x Nichia
DELIVERED LUMENS	1273 lumens	1991 lumens
SYSTEM WATTAGE	22W	30W
CRI	80+ CRI or 90+ CRI	
CCT	2700K, 3000K, 3500K or 4000K 3-step MacAdam ellipse binning	
LIGHT DISTRIBUTION	Semi-direct and ambient illumination	
DIFFUSOR	Thermoformed and frosted white PMMA	
STRUCTURE	Die-spun steel dish, available in white architectural grade fine textured finish	
VOLTAGE	120V (DP) or 120-277V (DV)	
DIMMING	Phase dimming (DP) and 0-10V dimming (DV)	
WARRANTY	5 years	

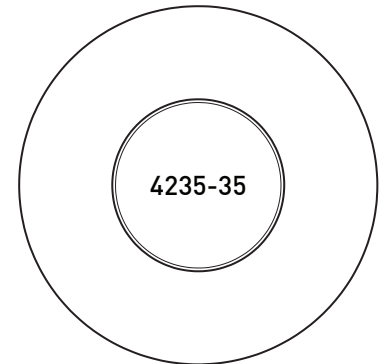
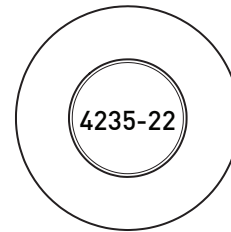
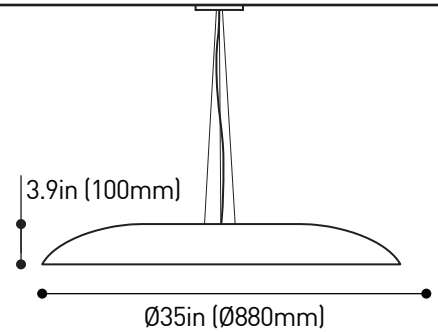
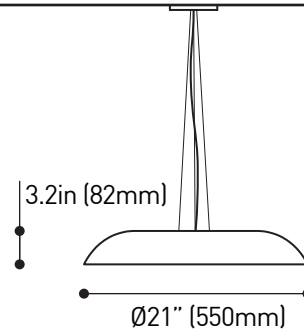
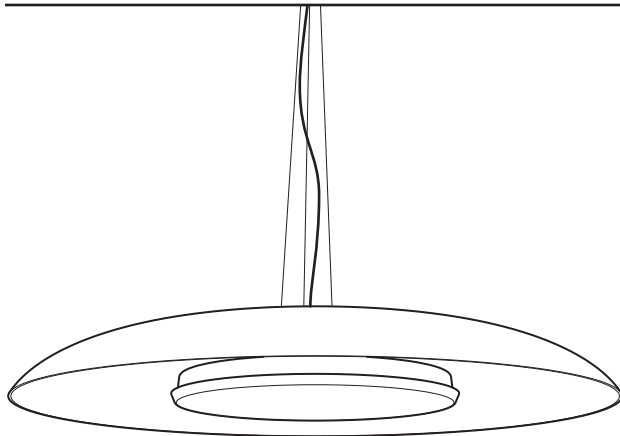
**LUMIÈRE INDIRECTE**

Luminaire conçu pour un éclairage principal indirect avec une illumination ambiante indirecte, permettant une versatilité dans plusieurs contextes d'installations.

**SYSTÈME D'INSTALLATION**

Pavillon magnétique et sans vis pour une installation plus simple et rapide.

**3 CABLES DE SUSPENSION**

Installation et ajustement simple.

**HAUTE DIFFUSION**

Diffuseur moulé sur mesure en PMMA blanc givré pour une lumière douce et uniforme.

**MODULES DEL HAUTE PERFORMANCE**

Modules DEL (bandes) conçu sur mesure pour un total de 22W ou 30W.

**FAÇADE**

Fait d'acier repoussé et offert avec notre finition architecturale finement texturée blanche.

**CARACTÉRISTIQUES 4235-22**

SOURCE LUMINEUSE	78 x Nichia
LUMENS RÉELS	1273 lumens
WATTAGE DU SYSTEM	22W
IRC	80+ IRC ou 90+ IRC
CCT	2700K, 3000K, 3500K ou 4000K 3 ellipses MacAdam
DISTRIBUTION LUMINEUSE	Illumination semi-direct et ambiante
DIFFUSEUR	PMMA blanc thermoformé et givré
STRUCTURE	Acier repoussé, fini architecturale finement texturée blanche
VOLTAGE	120V (DP) ou 120-277V (DV)
GRADATION	Gradation "phase" (DP) et gradation "0-10V" (DV)
GARANTIE	5 ans

**4235-35**

SOURCE LUMINEUSE	156 x Nichia
LUMENS RÉELS	1991 lumens
WATTAGE DU SYSTEM	30W