

OUTLINE SURFACE 46900

PROJECT PROJET
SPEC TYPE
NOTES

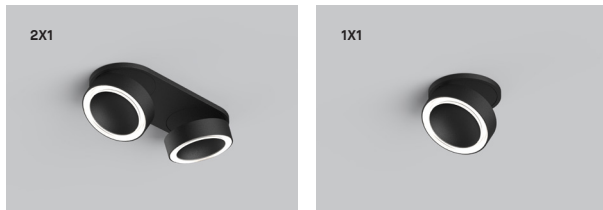

FINISH FINI



BLKE

WHE

FAMILY FAMILLE



RECESSED (12900)

SUSPENDED AIMABLE (74900)

SUSPENDED FIXED (74901)

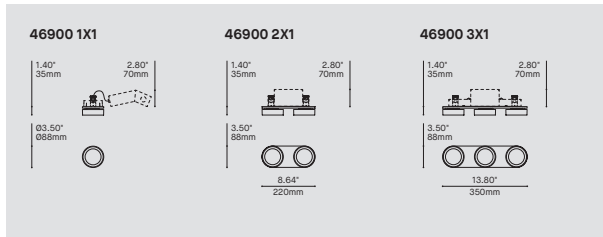

ORDERING SPECIFICATION SPÉCIFICATION DE COMMANDE

CODE

MODEL MODÈLE

46900-1X1	OUTLINE SURFACE 1X1
46900-2X1	OUTLINE SURFACE 2X1
46900-3X1	OUTLINE SURFACE 3X1

LIGHT SOURCE SOURCE LUMINEUSE

LED	REGULAR OUTPUT (IC RATED)
LED.HO	HIGH OUTPUT (NON-IC RATED)

COLOR TEMPERATURE TEMPÉRATURE DE COULEUR

27*	2700K
30	3000K
35	3500K
40	4000K

* LONGER LEAD TIME MAY APPLY, PLEASE CONTACT YOUR EUREKA REPRESENTATIVE

COLOR RENDERING INDEX (CRI) INDICE DE RENDU DE COULEUR (IRC)

80	80+ CRI
90*	90+ CRI

* LONGER LEAD TIME MAY APPLY, PLEASE CONTACT YOUR EUREKA REPRESENTATIVE

VOLTAGE VOLTAGE

120V	120 VOLT
277V	277 VOLT

DIMMING OPTION OPTION DE GRADATION

DV	0-10V DIMMING (120V-277V)
DP	PHASE DIMMING (120V ONLY)

LED DIMMING DRIVER IS STANDARD IN THIS PRODUCT, PLEASE SPECIFY YOUR DIMMING TYPE

EMERGENCY BATTERY BATTERIE D'URGENCE

INSTALLED REMOTELY. SEE EM GUIDE FOR DETAILS.

EMB*	EMERGENCY BATTERY FOR REMOTE BOX
------	----------------------------------

* 3981EA ACCESSORY IS REQUIRED

BEAM ANGLE ANGLE DE FAISCEAU

ME	MEDIUM (30°)
----	--------------

ME

ENCLOSURE FINISH FINI BOÎTIER

BLKE	BLACK FINE TEXTURE
WHE	WHITE FINE TEXTURE

EMERGENCY BATTERY ACCESSORY ACCESSOIRE BATTERIE D'URGENCE

3981EA	ELECTRICAL BOX FOR EMB EMERGENCY BATTERY
--------	--

PRODUCT CHARACTERISTICS CARACTÉRISTIQUES DU PRODUIT

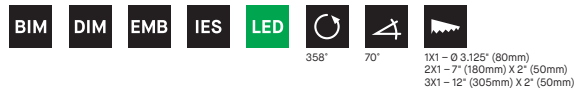

- DESIGN:** Outline is a modern and distinctive luminaire that creates a bold graphic statement. It exhibits a willingness to challenge traditional notions of projector-type lighting design. Each projector is equipped with a pivot that gives it a broad range of rotation and tilt.
- INSTALLATION:** With its recessed driver and connection box, the Outline surface version is quickly and securely installed on the ceiling with spring arms.
- STRUCTURE:** A machined plate and injected aluminium projectors coated in a high-quality fine texture finish.
- OPTIC:** The patent-pending Halo lens combined with the glare-control ring create a uniform light beam with a smooth cut-off.
- CERTIFIED:** c-CSA-us
- CONCEPTION:** Outline est un luminaire au design moderne, distinctif et graphique, qui redéfinit le concept typique de projecteur. Sa grande liberté d'orientation lui permet de mettre en valeur autant un mur qu'un couloir, et tout ce qui se trouve entre les deux.
- INSTALLATION:** Grâce à la boîte de connexion encastrée et le système de bras à ressort, la version surface s'installe facilement et rapidement.
- STRUCTURE:** Une plaque machinée jumelée à des projecteurs en aluminium revêtus d'une finition à texture fine de haute qualité.
- OPTIQUE:** La lentille Halo en attente de brevet et l'anneau anti-éblouissement produisent un faisceau de lumière parfaitement contrôlé avec une coupure en douceur.
- CERTIFIÉ:** c-CSA-us

OUTLINE SURFACE 46900

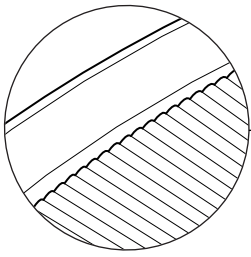

A UNIQUE LENS

The innovative lens offers a uniform light beam with great glare control and optical efficiency.

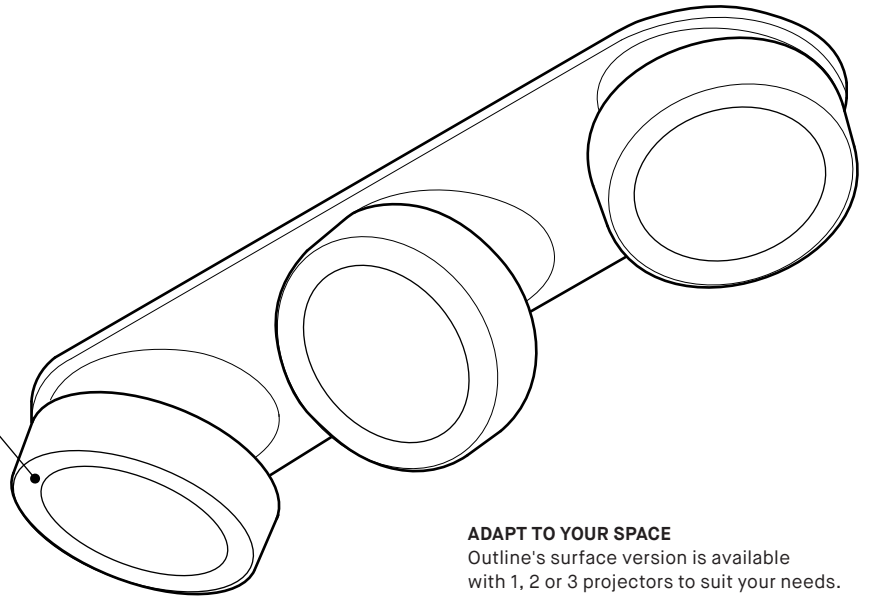

ADAPT TO YOUR SPACE

Outline's surface version is available with 1, 2 or 3 projectors to suit your needs.

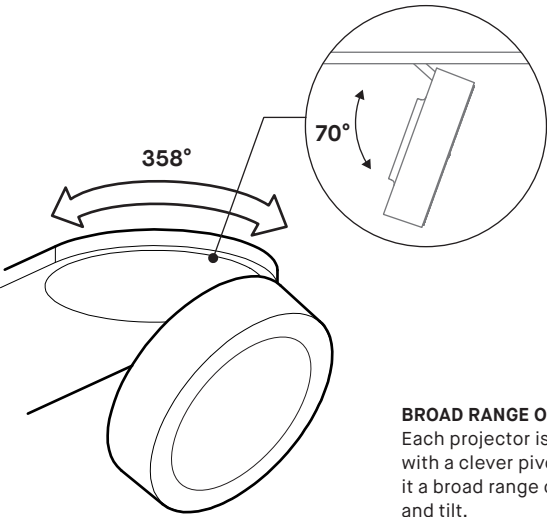

BROAD RANGE OF MOTION
Each projector is equipped with a clever pivot that gives it a broad range of rotation and tilt.

EASY INSTALLATION

Outline is quickly and securely installed on the ceiling with the help of spring arms.

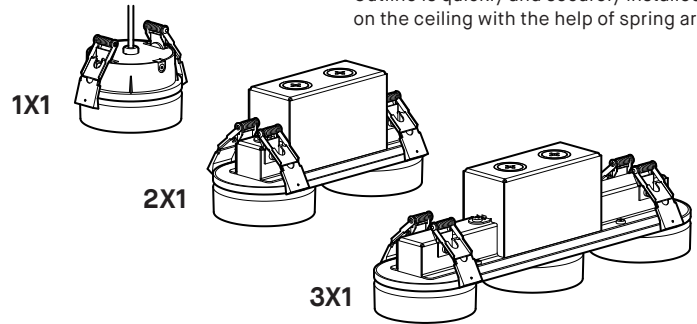

PRODUCT SPECIFICATION	46900-1X1 REG — HO	46900-2X1 REG — HO	46900-3X1 REG — HO
PERFORMANCE			
SYSTEM WATTAGE	10.1 W — 15.2 W	18.6 W — 29.6 W	27.5 W — 44.6 W
DELIVERED LUMENS (4000K - WHE)	764 LM — 1245 LM	1528 LM — 2486 LM	2292 LM — 3729 LM
EFFICACY	75 LM/W — 82 LM/W	82 LM/W — 84 LM/W	83 LM/W — 84 LM/W
OTHER INFORMATION			
LUMINAIRE'S WEIGHT (UP TO)	1.1 LBS / 0.5 KG	2.9 LBS / 1.3 KG	4.4 LBS / 2.0 KG

EFFICACY MULTIPLIERS

CRI	CCT	FACTOR
80+	4000K	1.00
80+	3500K	0.94
80+	3000K	0.94
80+	2700K	0.94
90+	4000K	0.87
90+	3500K	0.81
90+	3000K	0.81
90+	2700K	0.74

LIGHT DISTRIBUTION

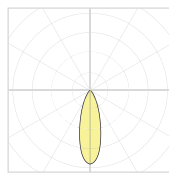

PROJECTOR



Visit our website for warranty terms and conditions.



TECHNICAL DATA

OUTLINE SURFACE 46900

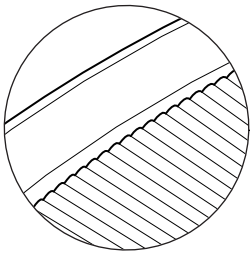

UNE LENTILLE UNIQUE

La conception innovante de la lentille permet de réduire les éblouissements et de produire un faisceau lumineux uniforme, tout en offrant une bonne efficacité optique.

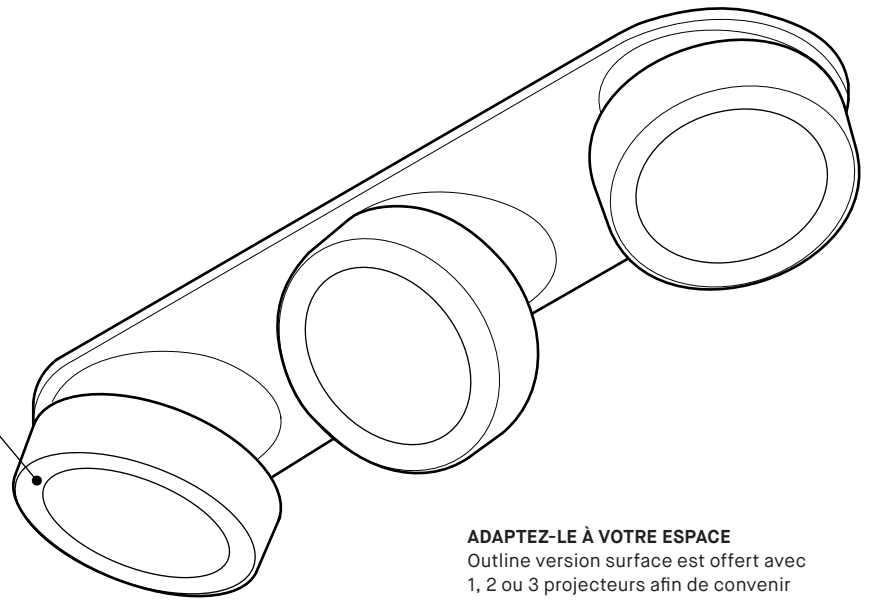

ADAPTEZ-LE À VOTRE ESPACE

Outline version surface est offert avec 1, 2 ou 3 projecteurs afin de convenir à vos besoins.

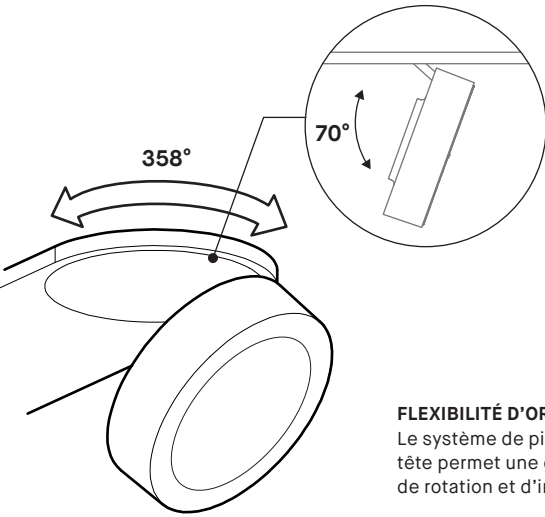

FLEXIBILITÉ D'ORIENTATION

Le système de pivot de chaque tête permet une grande latitude de rotation et d'inclinaison.

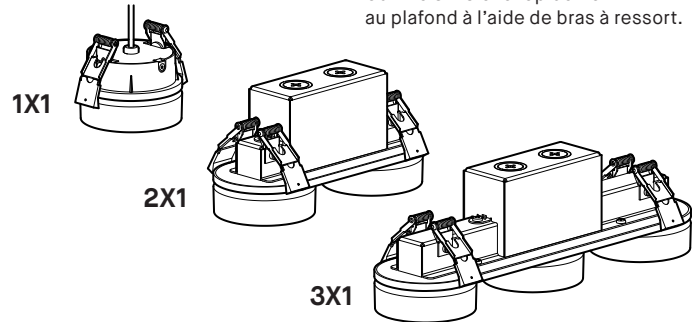

INSTALLATION FACILE

Outline s'installe rapidement au plafond à l'aide de bras à ressort.

SPÉCIFICATION PRODUIT

	46900-1X1 REG — HO	46900-2X1 REG — HO	46900-3X1 REG — HO
PERFORMANCE			
PUISSANCE TOTALE	10.1 W — 15.2 W	18.6 W — 29.6 W	27.5 W — 44.6 W
LUMENS RÉELS (4000K-WHE)	764 LM — 1245 LM	1528 LM — 2486 LM	2292 LM — 3729 LM
EFFICACITÉ	75 LM/W — 82 LM/W	82 LM/W — 84 LM/W	83 LM/W — 84 LM/W
AUTRE INFORMATION			
POIDS DU LUMINAIRE (JUSQU'À)	1.1 LBS / 0.5 KG	2.9 LBS / 1.3 KG	4.4 LBS / 2.0 KG

FACTEUR D'EFFICACITÉ

IRC	CCT	FACTEUR
80+	4000K	1.00
80+	3500K	0.94
80+	3000K	0.94
80+	2700K	0.94
90+	4000K	0.87
90+	3500K	0.81
90+	3000K	0.81
90+	2700K	0.74

DISTRIBUTION LUMINEUSE

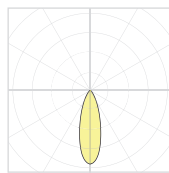

PROJECTEUR



Visitez notre site Web pour les termes et conditions.



DONNÉES TECHNIQUES